

1591A Enclosure

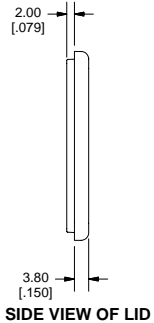

Note:
Enclosures can be Factory Modified (Milling, Drilling, Printing etc.)
Solid models of this enclosure available in STEP or IGES Format.
Contact Factory mjm@hammondmfg.com

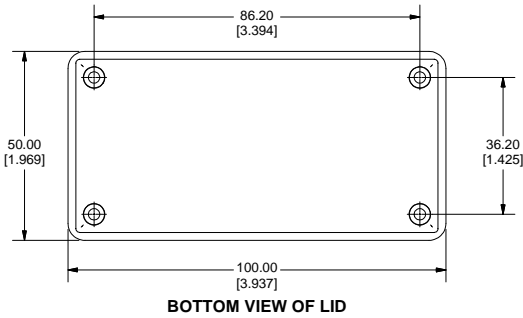
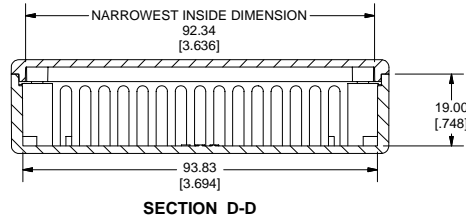
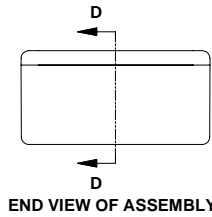
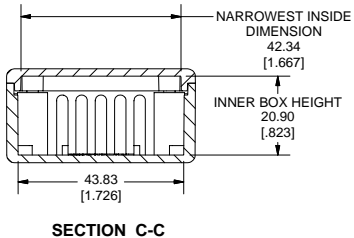
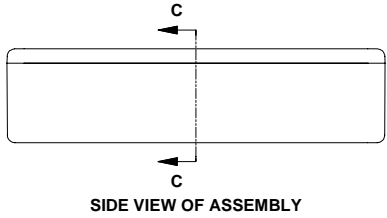
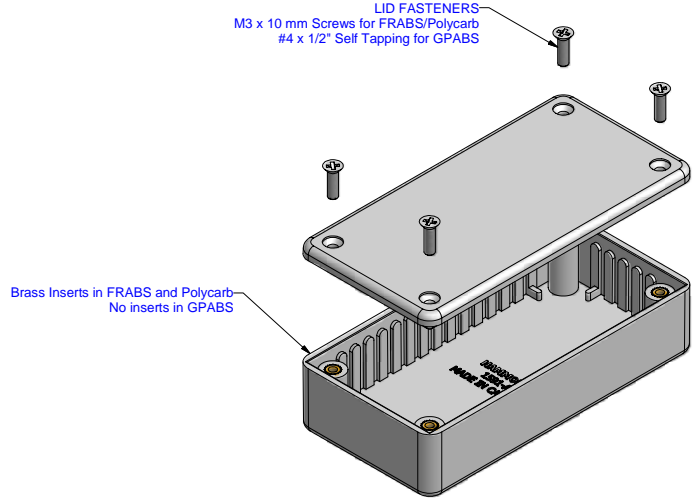
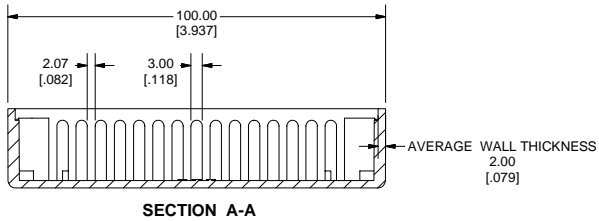
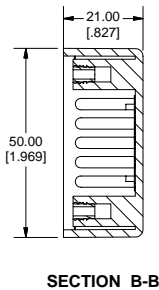
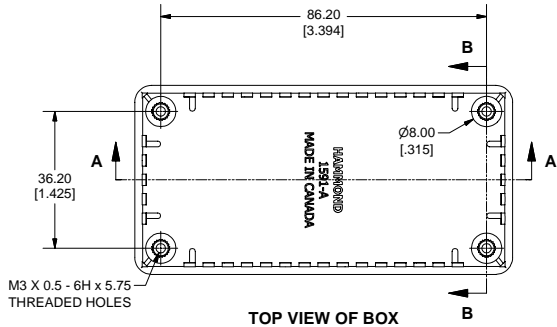
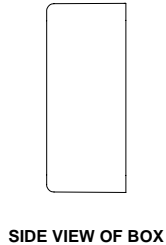

PART NUMBERS		
1591A Enclosures		
Material	Colour	Part Number
FR ABS UL94 - V0	Black	1591ABK
	Grey	1591AGY
GP ABS	Black Shielded (Conductive Paint)	1591RABK
	Black	1591ASBK
Translucent Polycarbonate	Grey	1591ASGY
	Ice Blue	1591ATBU
	IR Red	1591ATRD
	Crystal Clear	1591ATCL
Accessories		
	Description	Part Number
Universal Application	PC Board Card Adapters	See Accessories Section
	Flange Kits	See Accessories Section
	Clear Lids - clear, flame retardant polycarbonate - Lid ONLY	1591AC
FR ABS & Polycarbonate	Replacement Screws, Flat head Phillips, Nickel Plated Pkg of 100	1591MS100 1591MS100BK (Black)
GP ABS	Self Tapping Pkg of 100	1591TS100 1591TS100BK (Black)
Required Torque on Fasteners (no lubrication)		
	M3 - 0.5 x 10mm Screws	30-40 cN*m
	#4 x 0.5 Screws	30-40 cN*m